



Diversified Metal Fabricators Service Bulletin SB 2062

Title	RW-1015 Locking Valve & Orifice Disc Interference
Document No.	SB2062
Issue Date	07/29/2011 (BJF)
Release	General
Units Affected	RW-1015 units manufactured between July 2010 & June 22nd, 2011
Purpose	Provide guidance on identifying and replacing leaking Locking Valve Cartridges

Summary:

RW-1015 units with a Hydraforce locking valve (DC08-40), orifice disc, and Hydraforce manifold body (7024840) may leak down due to interference between the locking valve and orifice disc that prevents the cartridge from fully seating in the manifold body. The Parker locking valve (CPD084P) is shorter and will not interfere with the orifice disc.

Identification:

See Figure 1 for an example of each brand of locking valve.



Figure 1: Parker & Hydraforce Locking Valves

RW-1015 units manufactured prior to July of 2010 did not include orifice discs from the factory but some units were retrofitted with orifice discs once in service (to eliminate Railgear stuttering during deployment). RW-1015 units manufactured between July of 2010 and June 22nd of 2011 were built with Hydraforce locking valves and orifice discs. These units may have an external leak or an internal leak that prevents the Railgear from holding its stowed position. See Figure 2 for an illustration of the interference.



Diversified Metal Fabricators Service Bulletin SB 2062

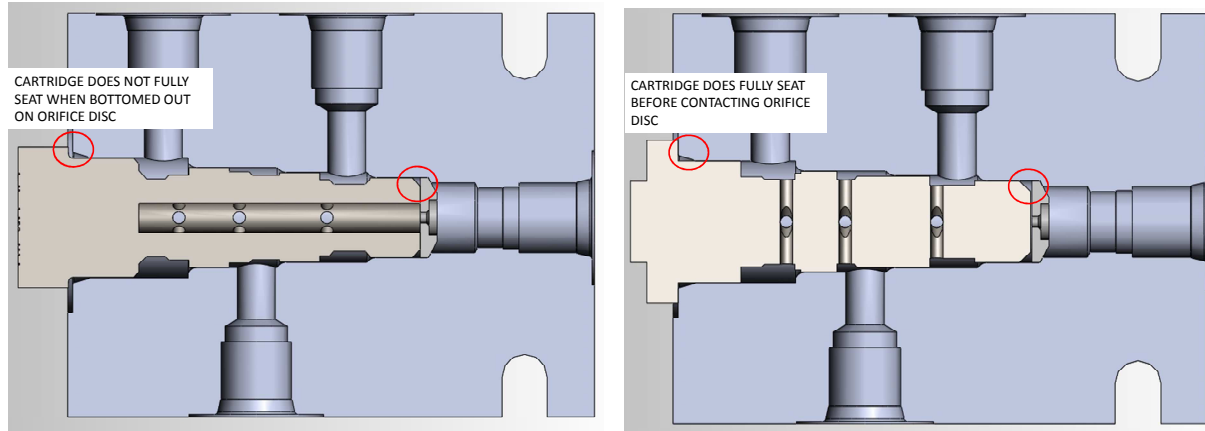

Figure 2: Hydraforce Locking Valve (Left) & Parker Locking Valve (Right)

The Parker locking valve is DMF part number 241016 (Parker # CPD084P). The .070" orifice disc used on RW-1015 is DMF part number 600613. Please have your DMF Railgear serial number and vehicle unit number ready when ordering parts.

Locking Valve Replacement:

1. Before starting work, lower the front and rear Railgear until it just touches the ground. This will reduce the pressure in the hydraulic lines and prevent the Railgear axle from falling during maintenance on the hydraulic system.
2. Remove existing Hydraforce locking valves (one for the front Railgear and one for the rear).
3. Remove orifice disc (if equipped).
4. Re-install orifice disc with beveled side facing inboard, away from the locking valve cartridge (see drawing 600611 below).
5. Coat the new Parker locking valve with Dexron III hydraulic fluid.
6. Carefully insert the Parker locking valve cartridge into the cavity and start the threads by hand.
7. Torque to 15 foot pounds.
8. Test Railgear function and check for leaks.

DMF will replace defective parts under DMF's warranty terms. DMF may require the return of affected parts to determine coverage.

Diversified Metal Fabricators

Phone: (404) 875-1512

Email: info@dmfatlanta.com

Web: www.dmfatlanta.com

ITEM NO.	PART NUMBER	QTY.	DESCRIPTION
1	600612	1	1015 LOCKING VLV BODY ONLY (7024840)
2	241016	1	VALVE, LOCKING, CPD-084P, PARKER
3	6801-4-4	2	04 JIC X 04 O-RING 90 FITTING
4	6400-04-04	2	04JIC MALE X 04 O-RING MALE
5	6602-04-04-04	2	T-#4JIC X #4JICF SWIVEL X #4JIC
6	600613	1	ORIFICE .070" (7051-070)

△ A

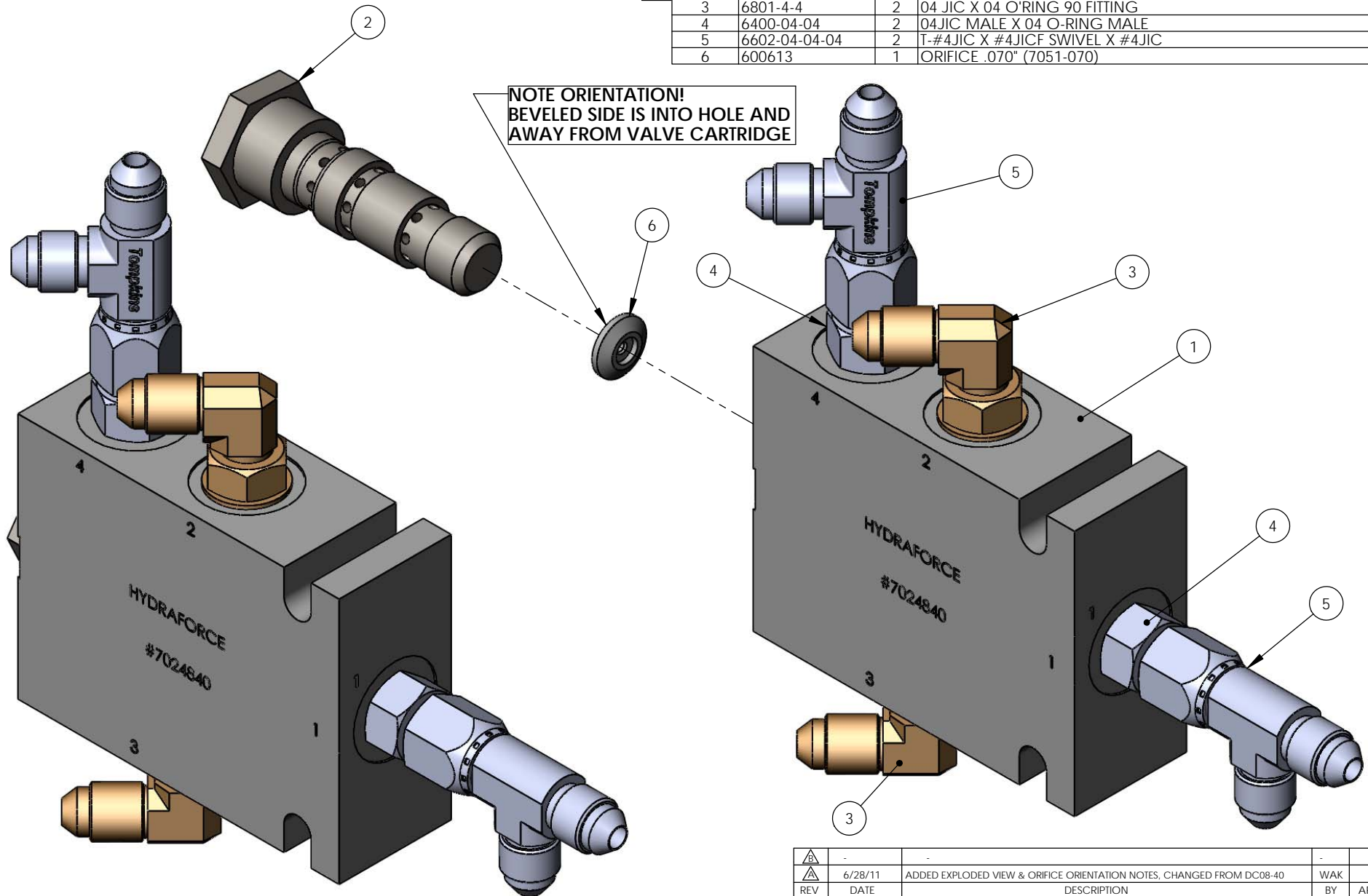

NOTE ORIENTATION!
BEVELED SIDE IS INTO HOLE AND AWAY FROM VALVE CARTRIDGE

△	-	-	-
△	6/28/11	ADDED EXPLODED VIEW & ORIFICE ORIENTATION NOTES, CHANGED FROM DC08-40	WAK
REV	DATE	DESCRIPTION	BY APP
TOLERANCES: (UNLESS SPECIFIED)		TITLE:	
FRAC. MACH:	± 1/32"	RW-1015	
FRAC. OTHER:	± 1/16"		
.XX	± .063	LOCKING VALVE W/ ORIFICE & FITTINGS	
.XX	± .030		
.XXX	± .005	DIVERSIFIED METAL FABRICATORS, INC. (404) 875-1512	
DRILL SIZES:	± .015	DRAWN BY:	APPD BY:
ANGULAR:	± 1°	JBG	
SURF FINISH:	125 MICRO	DATE:	8/19/2010
THREADS:	2A AND 2B	DRAWING NUMBER:	600611
<small>© 2011 DIVERSIFIED METAL FABRICATORS, INC. (404) 875-1512</small>			REV: A