



Diversified Metal Fabricators Service Bulletin SB 2047:

Title	RW-1019 Washer Issue for 2005 and Newer Ford F-450/550's
Document No.	SB 2047
Issue Date	3/15/06 (WAK) Revised 4/24/06
Units Affected	Model year 2005 and newer Ford F-450s and F-550s
Purpose	This service bulletin addresses an installation error regarding RW-1019 front railgear on model year 2005 and newer Ford F-450's and F-550's.

Summary:

DMF shipped sets of RW-1019 railgear for model year 2005 and newer Ford F-450/550s without the proper washers for the rear long arm pins on the front rail gear. The installation instructions do not address the washers or their location, so most installers were unaware that the washers were missing from the railgear kit.

Process:

Identify Units with Missing Pin Off Fender Washers

The illustration below shows the cable operated pin off assembly for RW-1019 railgear which is standard on models for 2005 and newer Ford F-450/550s. There should be a fender washer installed between the remote cable operator and the actual pin itself. The washer prevents the pin from being over inserted into the guide tube. Over insertion can allow the pin to become cockeyed in the guide tube and snap the pin-off cable where it threads into the pin.

If there is no washer, a new one must be installed.

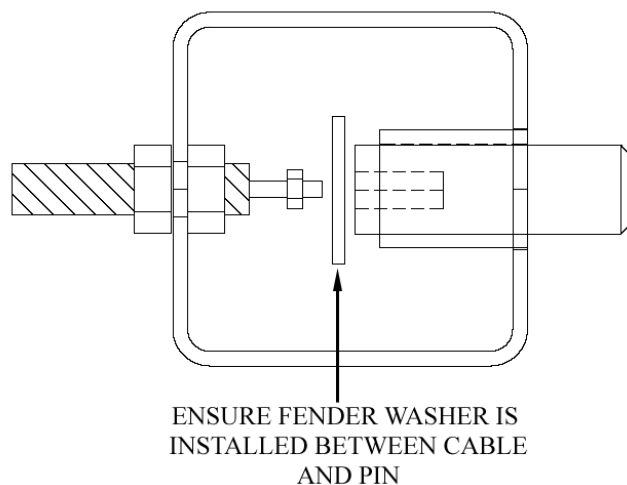



Diversified Metal Fabricators Service Bulletin SB 2047:

Identify Units with Missing Washers

The picture below shows the driver's side of a front set of RW-1019 railgear for a 2005 model year Ford F-450/550. For each side of the truck there are supposed to be 3 washers for the rear pin. There is supposed to be a 1-1/4" washer between each long arm and the spring bracket bolted to the radius arm. Additionally there should be a 1" washer between the inner long arm and the castellated nut.

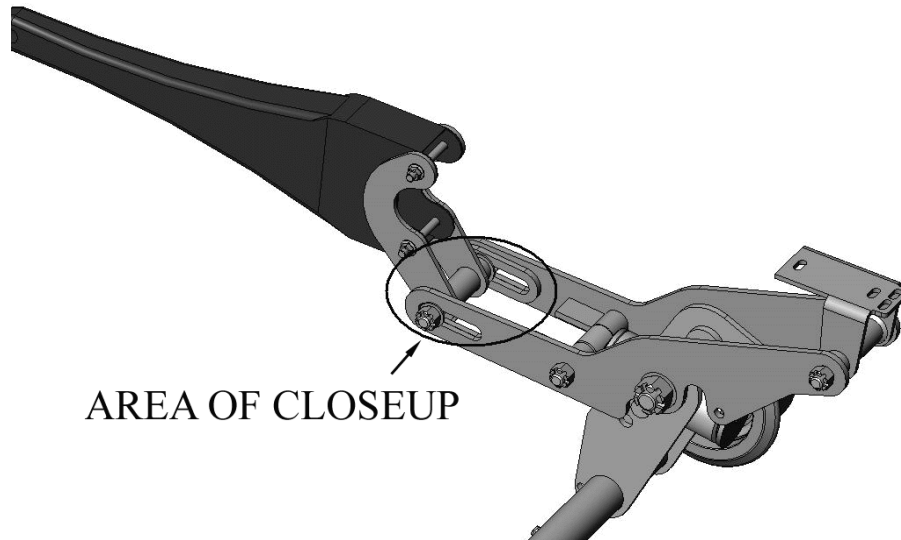

Please see the close-up diagram below for proper washer location.

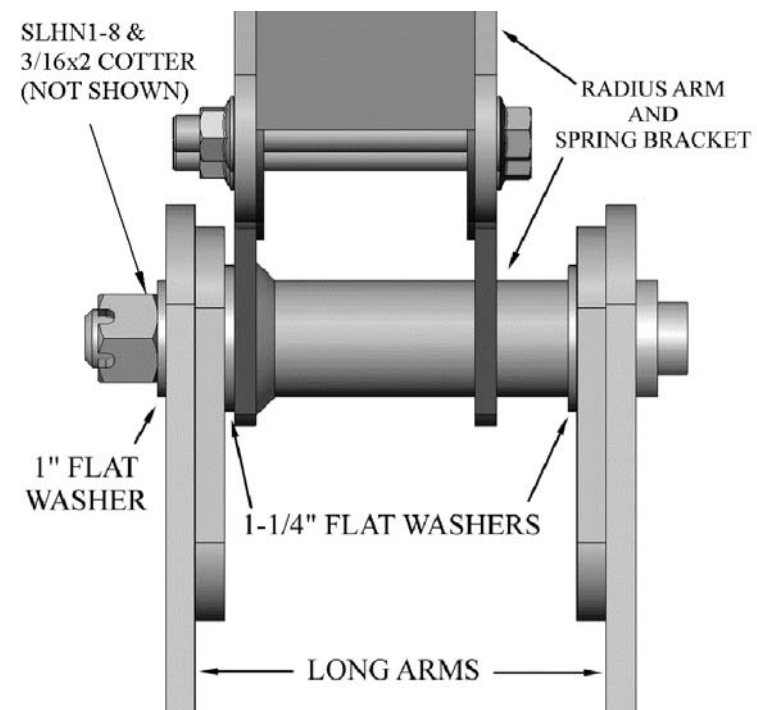



Diversified Metal Fabricators Service Bulletin SB 2047:

Identifying excessively worn Long Arms

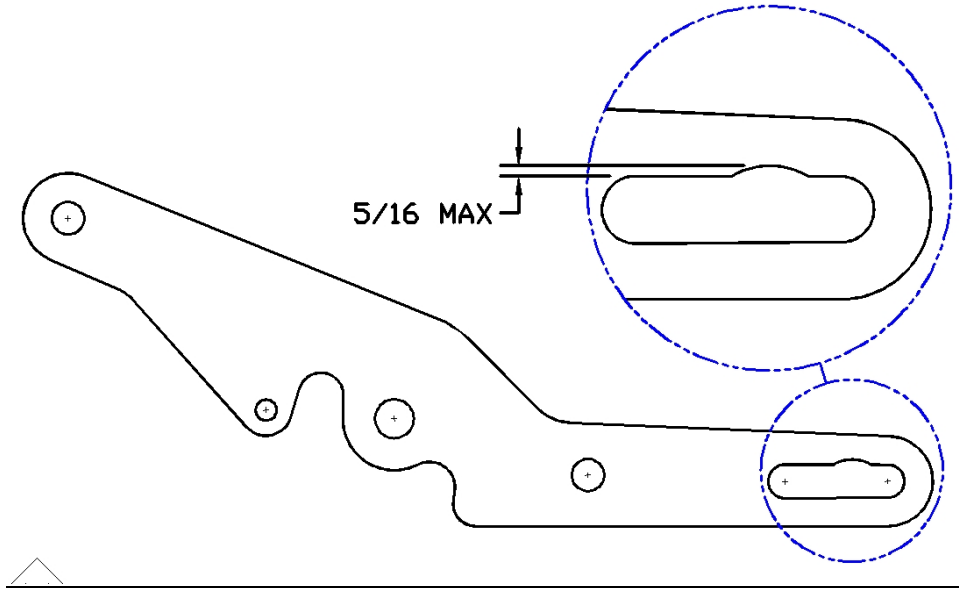

Repair Affected Units

- Inspect slotted area of each long arm for excessive wear as shown above. Replace if necessary.
- Inspect 1" Slotted nut for excessive wear. Replace if necessary.
- Any unusual or excessive wear should be directed to DMF engineering for evaluation.
- All warranty claims must reference the railgear's serial number.

Repair Kit

DMF Part Number 11327 contains:

QTY	Item	Description
2	FW1	Flat Washer 1"
4	FW1-1/4	Flat Washer 1-1/4"
2	SLHN1-8	Slotted Hex Nut 1-8UNC
2	Cotter3/16x2	Cotter Pin 3/16x2
2	FW1/4 Fender Fender Washer ¼ (1-1/4 OD)	

DMF Part Number 11321 is the Passenger's Side Long Arm Weldment

DMF Part Number 11322 is the Driver's Side Long Arm Weldment

DMF will replace defective parts under DMF's warranty terms. DMF will not cover parts that have been subjected to gross overloading or blatant abuse. DMF may require the return of affected parts to determine coverage. All warranty claims must include the railgear serial number.

Diversified Metal Fabricators

Phone: (404) 875-1512

Email: info@dmfatlanta.com

Web: www.dmfatlanta.com