



Diversified Metal Fabricators Service Bulletin SB 2051

Title	RW-1019 Long Arm Slots Issues for 2005-2008 Ford F-450/550's
Document No.	SB 2051
Issue Date	8/13/07 (WAK)
Units Affected	2005-2008 Ford F-450s and F-550s
Purpose	This service bulletin addresses a product improvement for RW-1019 front railgear on model year 2005 and newer Ford F-450's and F-550's.

Summary:

In order to improve resistance to wear on pins, RW-1019 railgear for '05-'08 Ford F4/550 has been re-designed. Units with any configuration of slots (front, rear, with or without slidebars) should be converted to the current configuration. The current configuration uses a swinging link to replace the pin/slot.

Any and all labor charges must be pre-approved by DMF's service department. Contact Matt Harbison at 404-786-1513.

Process:

Identify units requiring updated parts

The following longarms should be replaced:

- Longarms with front slots
- Longarms with rear slots with or without guide rails & slide bars (see Fig. 1)

These arms will be replaced with new longarms and will be provided with new rear pins, washers and nuts. The axle brackets rear pins will also be replaced.

The DMF part numbers for the retrofit kits are:

11364 Retrofit kit for '08 and later F4/550's
11393 Retrofit kit for '05-'07 F4/550's

The only difference between the '05-'07 kits and the '08 kits are the front end of the long arm and the front bracket due to differences in the frame ends. The front bracket is re-used as is.



Diversified Metal Fabricators Service Bulletin SB 2051

Replace Arms

The following procedure can be used in the field with little equipment. This may be accomplished more easily in a shop with jacks, jack stands, forklifts, hoists, etc.

Note: Longarms are replaced in pairs – one side at a time.

Note: Replace all cotter pins with those provided.

1. Remove safety pins-offs.
2. Lower railwheels to ground.
3. Place wood blocking under driver side cylinder.
4. Remove front and rear pins for drive side longarms.
5. Remove existing driver side axle bracket.
6. Install new axle bracket plates with provided M18 bolts, washers and nylock nuts (do not reuse nylock nuts).
7. Install swing link with the provided short pin. The longer side of the link should face outward.
8. Install new longarms on the cylinder trunnion and new rear pin. Reuse cylinder trunnion hardware except cotter pin.
9. Use railgear hydraulics to position front of longarm and replace front pin.
10. Repeat step 2-7 for passenger side.
11. Grease all (8) grease fittings
12. Stow and pin off.

Verify Operation & Alignment

1. Verify pin operation.
2. Verify that all hydraulic lines are properly restrained and supported.
3. Check alignment and adjust as necessary per manual.
(Manual can be downloaded at: <http://www.dmfatlanta.com/techinfo/>)

It is not necessary to send replaced parts to DMF unless specifically asked to. Please scrap used longarms and pins. Do not reuse the pin that was in the slot for any other purpose. Contact DMF if you have any questions.



Diversified Metal Fabricators
Service Bulletin SB 2051

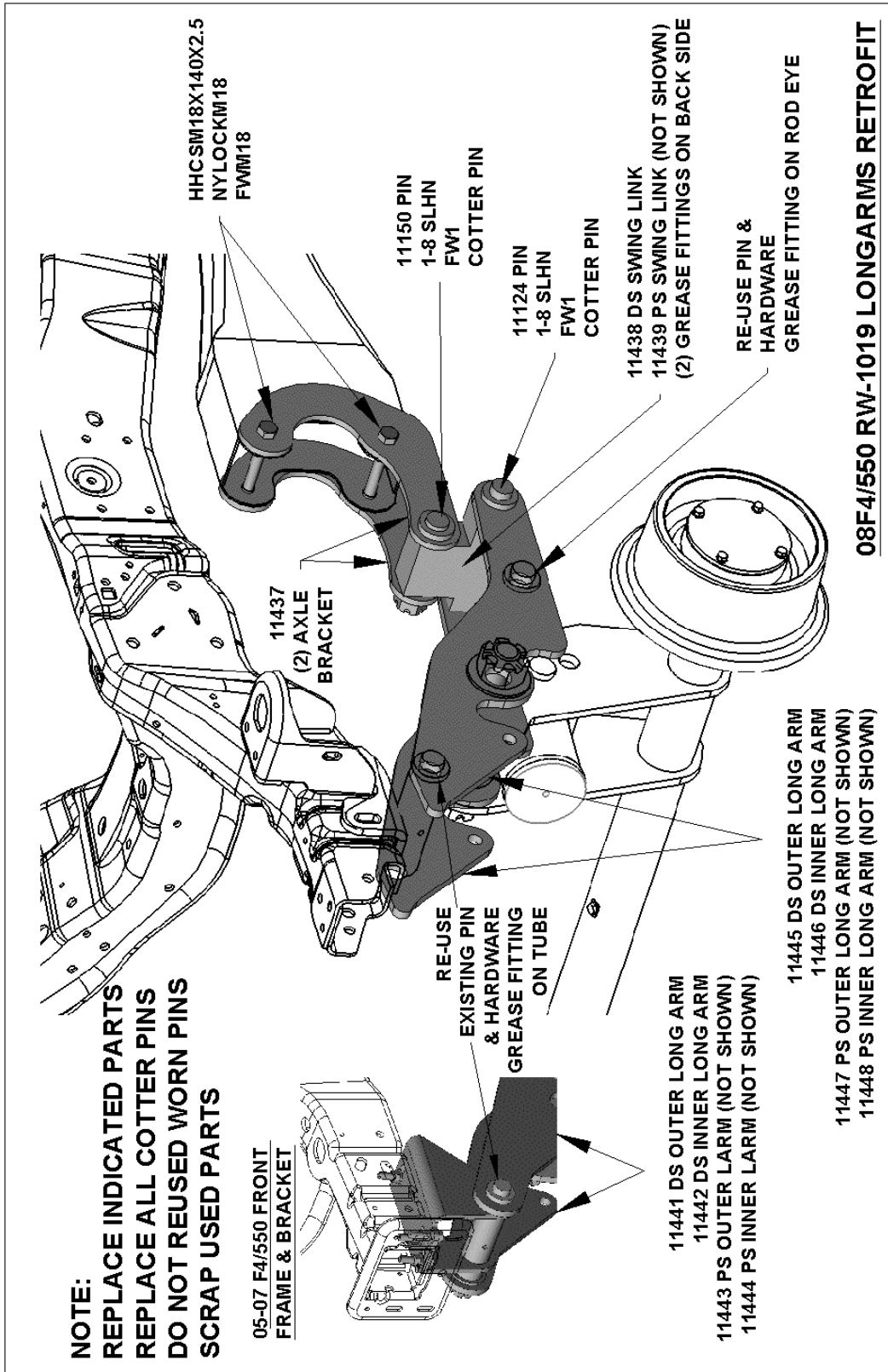

Fig. 1: New Longarms



**Diversified Metal Fabricators
Service Bulletin SB 2051**

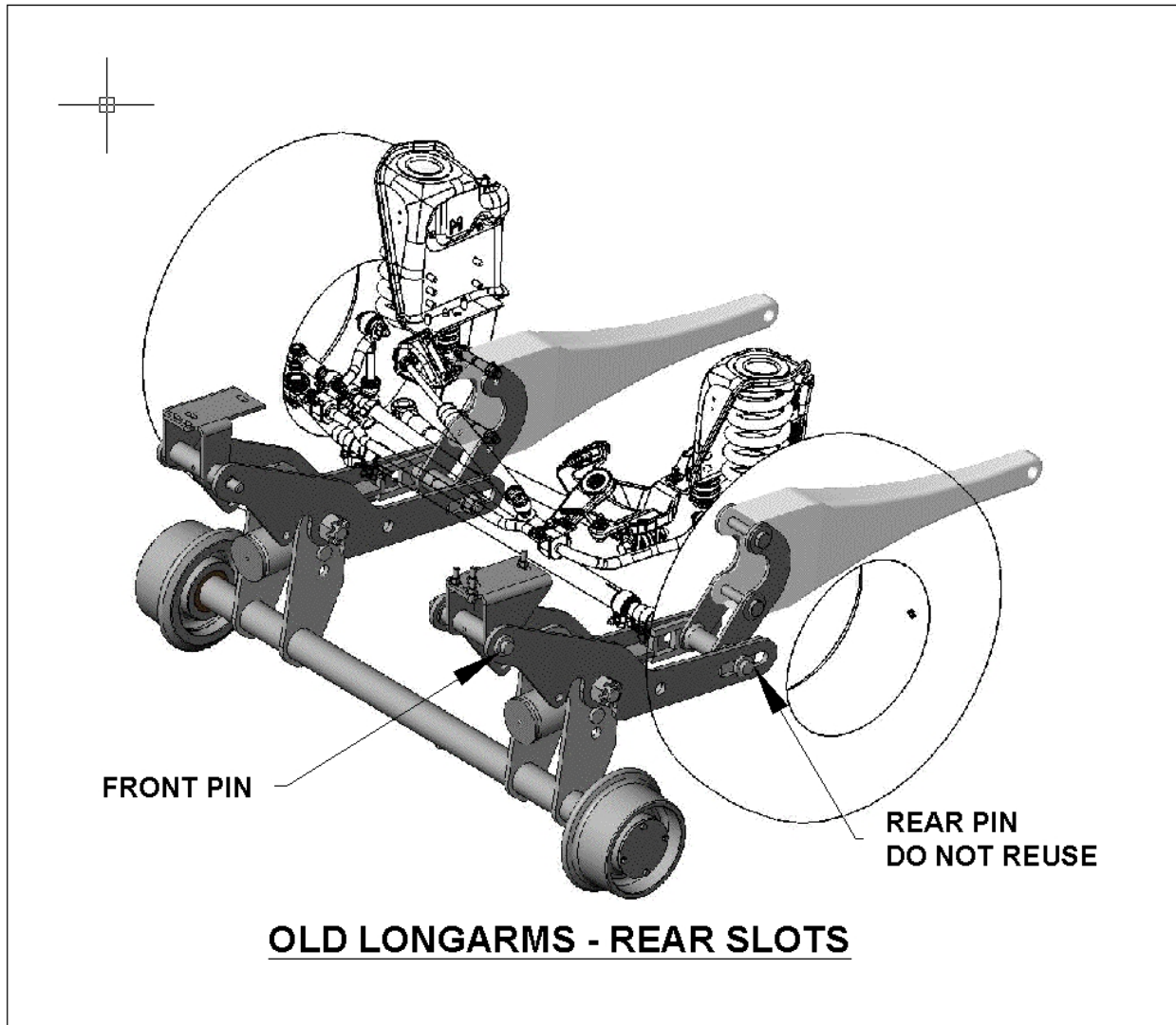

Fig. 2: Old Longarms

DMF will replace defective parts under DMF's warranty terms. DMF will not cover parts that have been subjected to gross overloading or blatant abuse. DMF may require the return of affected parts to determine coverage.

Diversified Metal Fabricators
Phone: (404) 875-1512
Email: info@dmfatlanta.com
Web: www.dmfatlanta.com